

8260 Nways Multiprotocol Switching Hub
8265 Nways ATM Switch
8285 Nways ATM Workgroup Switch



ATM WAN 2 and WAN 2.5 Modules I/O Card Installation Guide

8260 Nways Multiprotocol Switching Hub
8265 Nways ATM Switch
8285 Nways ATM Workgroup Switch



ATM WAN 2 and WAN 2.5 Modules I/O Card Installation Guide

Note!

Before using this information and the product it supports, be sure to read the general information under Appendix B, "Notices" on page 35.

Third Edition (September 1998)

The information contained in this manual is subject to change from time to time. Any such changes will be reported in subsequent revisions.

Order publications through your IBM representative or the IBM branch office serving your locality. Publications are not stocked at the address given below.

You may address your comments on this publication to:

IBM France
Centre d'Etudes et Recherches
Service 0798 - BP 79
06610 La Gaude
France

- FAX: 33 4 93 24 77 97
- IBM Internal Use: LGERCF at IBMFR
- Internet: lgercf@fr.ibm.com

When you send information to IBM, you grant IBM a non-exclusive right to use or distribute the information in any way it believes appropriate without incurring any obligation to you.

© **Copyright International Business Machines Corporation 1996, 1998. All rights reserved.**

Note to U.S. Government Users — Documentation related to restricted rights — Use, duplication or disclosure is subject to restrictions set forth in GSA ADP Schedule Contract with IBM Corp.

Contents

Figures	v
Tables	vii
Chapter 1. Overview	1
Chapter 2. Unpacking and Checking the Shipping Group	3
Shipping Group Contents	3
E1/T1/J1 I/O Card or E1/T1/J1 IMA I/O Card	3
E3, DS3, OC3, and STM1 I/O Cards	3
Before Unpacking the I/O Card	4
Unpacking the Module or I/O Cards	4
Chapter 3. Installing an E1/T1/J1 or E1/T1/J1 IMA I/O Card	5
Procedure	5
Jumpers and Ports on the E1/T1/J1 and E1/T1/J1 IMA I/O Card	6
Setting the Connection Jumpers	8
Setting the Grounding Jumpers	9
E1 and T1/J1 Twisted-Pair Connections	9
E1 Coaxial Connections	9
Mounting an E1/T1/J1 or E1/T1/J1 IMA on the Motherboard	10
Chapter 4. Installing an E3, DS3, OC3, or STM1 I/O Card	15
Procedure	15
Setting the Grounding Jumpers for E3/DS3 I/O Cards	16
Mounting an E3, DS3, OC3, or STM1 on the WAN Motherboard	18
Appendix A. Technical Information	23
E1/T1/J1 and E1/T1/J1 IMA I/O Card	23
Cabling Information	23
Cabling Distances	23
E3/DS3 I/O Cards	25
Cabling Information	25
Cabling Distances	25
OC3/STM1 I/O Cards - Single Mode	26
Optical Power Budget	26
Optical Power Loss through Connectors	26
Optical Power Loss through Splicing	26
Optical Power Loss by Fiber Cable Type	26
Optical Power Loss through Patch Panels	27
Optical Power Loss through Jumper Cables	27
SC Single Mode Transmitters	27
SC Single Mode Receivers	28
OC3/STM1 I/O Cards - Multimode	29
Optical Power Budget	29

Optical Power Loss through Connectors	30
Optical Power Loss through Splicing	30
Optical Power Loss by Fiber Cable Type	31
Optical Power Loss through Patch Panels	31
Optical Power Loss through Jumper Cables	31
SC Multimode Transmitters	32
SC Multimode Receivers	33
Appendix B. Notices	35
Product Page/Warranties	35
Trademarks	35
Safety	35

Figures

1.	Port and Jumper Locations on the E1/T1/J1 I/O Card	6
2.	Port and Jumper Locations on the E1/T1/J1 IMA I/O Card	7
3.	Port Connection Jumper Settings	8
4.	Removing the Motherboard	10
5.	Removing the Dummy Faceplate Bracket	11
6.	Attaching the I/O Card	11
7.	Attaching the Faceplate Bracket	12
8.	Reattaching the Motherboard	13
9.	Grounding Jumper Locations	16
10.	Removing the Motherboard	19
11.	Removing the Dummy Faceplate Bracket	20
12.	Attaching the I/O Card	20
13.	Attaching the Faceplate Bracket	21
14.	Reattaching the Motherboard	22

Tables

1.	Port Connection Jumpers	8
2.	Ground Jumper Settings for E1 Coaxial Connections	9
3.	Grounding Jumper Requirements for E3/DS3 I/O Cards.	17
4.	E1/T1/J1 Cabling	23
5.	ATM Device Cabling Distances	24
6.	Cabling Details	25
7.	ATM Device Cabling Distances	25
8.	Optical Power Budget for Port-to-Port Connections: Single-Mode Fiber	26
9.	Optical Power Loss per Connector: Single-Mode Fiber	26
10.	Optical Power Loss per Splice: Single-Mode Fiber	26
11.	Optical Power Loss by Cable Type: Single-Mode Fiber	26
12.	Optical Power Loss per Patch Panel: Single-Mode Fiber	27
13.	Optical Power Loss per IBM Jumper Cable: Single-Mode Fiber	27
14.	Optical Specifications for SC Transmitters: Single-Mode Fiber	27
15.	Optical Specifications for SC Receivers: Single-Mode Fiber	28
16.	Optical Power Budget for Port-to-Device Connections: Multimode Fiber (ATM Forum V3.0)	29
17.	Optical Power Budget for Port-to-Port Connections: Multimode Fiber	29
18.	Optical Power Loss per Connector: Multimode Fiber	30
19.	Optical Power Loss per Splice: Multimode Fiber	30
20.	Optical Power Loss by Cable Type: Multimode Fiber	31
21.	Optical Power Loss per Patch Panel: Multimode Fiber	31
22.	Optical Power Loss per IBM Jumper Cable: Multimode Fiber	31
23.	Optical Specifications for SC Transmitters: Multimode Fiber	32
24.	Optical Specifications for SC Receivers: Multimode Fiber	33

Chapter 1. Overview

This manual describes the procedures for installing E1/T1/J1, E1/T1/J1 IMA, E3, DS3, OC3, and STM1 I/O cards on the following modules:

- IBM 8260/8265/8285 WAN 2 module, Feature Code 5602, and 5612 (Japan only)
- IBM 8265 WAN 2.5 module Feature Code 6561.

The IBM WAN 2 module functions as part of the IBM 8260 Nways Multiprotocol Switching Hub, IBM 8265 Nways ATM Switch, or IBM 8285 Nways ATM Workgroup Switch Expansion Unit.

The IBM WAN 2.5 module functions as part of the IBM 8265 Nways ATM Switch.

All I/O card interfaces conform to the relevant ATM Forum Specifications.

Throughout this manual, the term *WAN Module User's Guide* will be used, depending on the type of WAN module, for:

- *IBM ATM WAN 2 Module: Installation and User's Guide*, SA33-0436.
- *IBM 8265 Nways ATM Switch Media Module Reference Guide* SA33-0459.

Chapter 2. Unpacking and Checking the Shipping Group

This chapter describes the contents of the I/O card shipping groups, and describes how to unpack the I/O cards.

Shipping Group Contents

E1/T1/J1 I/O Card or E1/T1/J1 IMA I/O Card

When you receive your I/O card, the shipping group for each card contains:

- One I/O card, to be installed on the motherboard
- One Vital Product Data (VPD) Programmable Read Only Memory (PROM) chip, to be installed on the motherboard
- Six screws to secure the I/O card to the motherboard
- Two screwlock kits, one for each port
- One faceplate
- Two 'Y' cables for connecting up to 4 ports per I/O card. For the 8265, there are two sets of 'Y' cables, one set for twisted pair connections and one set for coaxial connections.

E3, DS3, OC3, and STM1 I/O Cards

When you receive your I/O card, the shipping group for each card contains:

- One I/O card, to be installed on the motherboard
- One Vital Product Data (VPD) Programmable Read Only Memory (PROM) chip, to be installed on the motherboard.
- Five screws: three for attaching the I/O card to the motherboard, and two for securing the I/O card to the front panel of the module.
- One motherboard faceplate bracket.
- One dummy port cover with screw, for use when only one I/O card is installed on a motherboard.

Before Unpacking the I/O Card

Take the following precautions before unpacking the I/O card:

- Do not remove the component from its anti-static shielding bag until you are ready to use it. This avoids the possibility of having electrostatic discharge damage static-sensitive devices on the component.
- When possible, handle the component by its faceplates.
- Always use a foot strap and grounded mat or wear a grounded static discharge wrist strap whenever you inspect or handle a component. Or else, be sure to touch a grounded rack or another source of ground **before** handling it.
- Ensure that you have a clean surface available on which to place the component.

Unpacking the Module or I/O Cards

When unpacking the I/O card, follow these steps:

— **1** Verify that the I/O card is the correct model by comparing the Feature Code listed on the side of the shipping carton with the Feature Code you ordered.

— **2** Remove the I/O card from its shipping carton.

— **3** Remove the I/O card from its anti-static bag and inspect it for damage. Always handle it by the faceplate being careful not to touch the internal components.

Be sure to keep the screws that come with the I/O card as you will need them to install the card on the motherboard.

If the I/O card appears to be damaged, put it back in the anti-static bag, and put the bag back into the shipping carton. Then contact your local IBM dealer.

IBM suggests that you keep the shipping carton and the anti-static shielding bags in which the I/O card was delivered in case you later want to repackage it for storage or shipment.

IBM also suggests that you record the serial number of the I/O card and other information about the modules, and keep safely with your WAN module details.

Chapter 3. Installing an E1/T1/J1 or E1/T1/J1 IMA I/O Card

This chapter describes the steps required to install an E1/T1/J1 or E1/T1/J1 IMA I/O card

Procedure

- **1** Adjust the port jumpers on the I/O card to correspond to the type of connection you will be using (E1 Coaxial, E1 Twisted-Pair, T1/J1 Twisted-Pair) by following the instructions in “Setting the Connection Jumpers” on page 8.
- **2** Ensure that the configuration of the grounding jumpers on the I/O card conforms to the type of port connection and to the specific grounding regulations in your country by following the instructions in “Setting the Grounding Jumpers” on page 9.
- **3** Mount the I/O card on the module by following the instructions in “Mounting an E1/T1/J1 or E1/T1/J1 IMA on the Motherboard” on page 10.
- **4** Configure the I/O card as described in the *WAN Module User's Guide*.
Note: If you replace an I/O card after configuring the module, the new card is automatically configured with the settings of the previous card when you re-insert the module.

Jumpers and Ports on the E1/T1/J1 and E1/T1/J1 IMA I/O Card

The location of the ports, configuration jumpers and grounding jumpers on the E1/T1/J1 and E1/T1/J1 IMA I/O cards are shown in Figures 1 and 2 respectively.

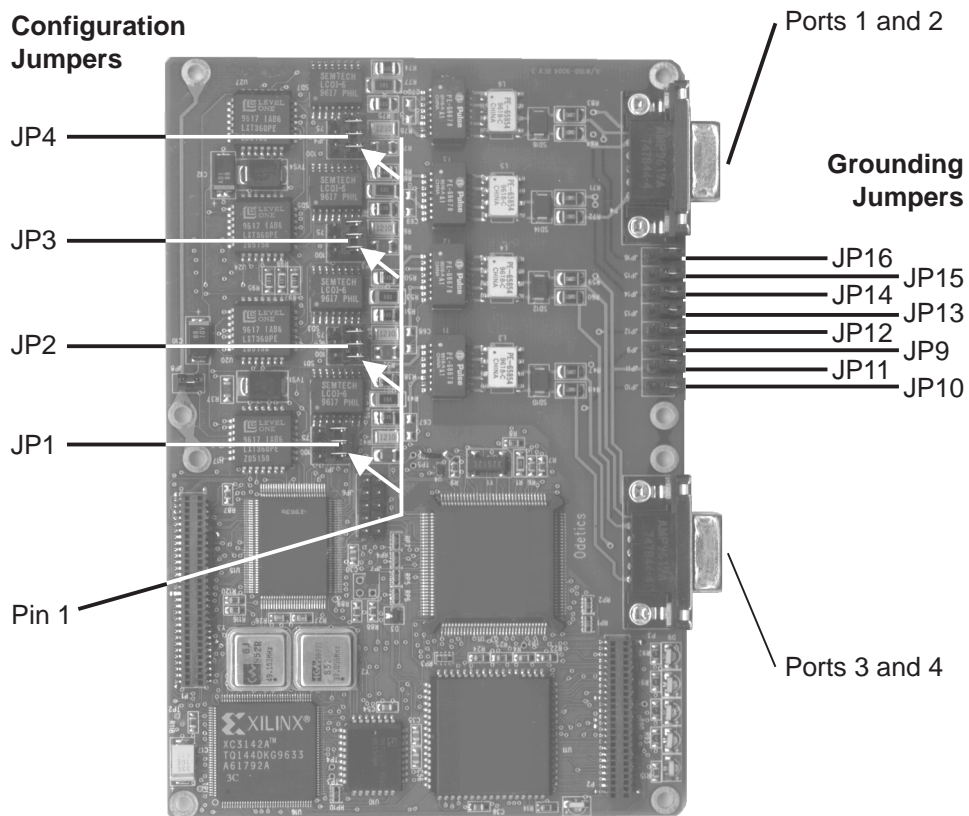

Figure 1. Port and Jumper Locations on the E1/T1/J1 I/O Card

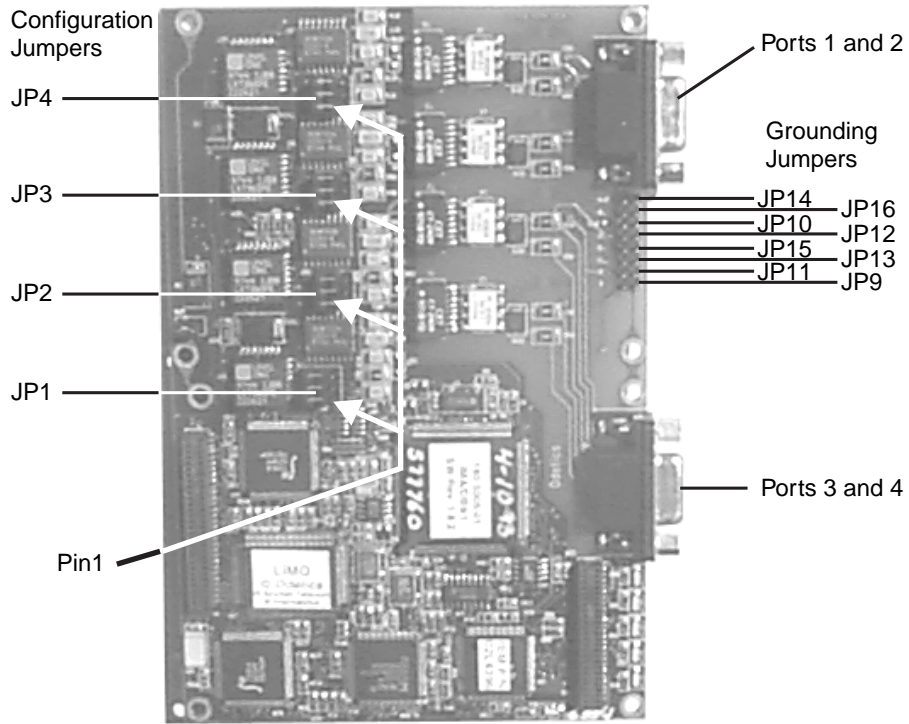

Figure 2. Port and Jumper Locations on the E1/T1/J1 IMA I/O Card

Setting the Connection Jumpers

Each E1/T1/J1 and E1/T1/J1 IMA I/O card has four Port Connection jumpers (JP1-JP4; see Figure 1 on page 6 and Figure 2 on page 7), which determine the types of connection you can attach to each of the ports:

- E1 Coaxial Connection
- E1 Twisted-Pair Connection
- T1/J1 Twisted-Pair Connection

Note: All ports on the same I/O card must be set up either:

- All as T1/J1 connections (twisted-pair), or
- All as E1 connections (any combination of coaxial or twisted-pair)

If E1 and T1/J1 connections are mixed on the same I/O card, NOT SUPPORTED PORT will be displayed.

Figure 3 shows the correct position of the jumper for each connection type.

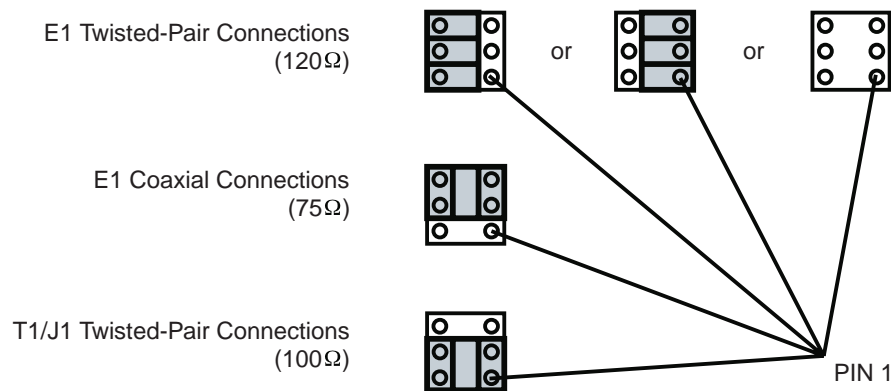

Figure 3. Port Connection Jumper Settings

Table 1. Port Connection Jumpers

Port Number:	Jumper Number:	Port Number:	Jumper Number:
Port 1	JP4	Port 3	JP2
Port 2	JP3	Port 4	JP1

Setting the Grounding Jumpers

E1 and T1/J1 Twisted-Pair Connections

Twisted-pair connections should not be grounded. You must remove the grounding jumpers from both the Transmit and the Receive jumper pins for each port that has a twisted-pair connection.

E1 Coaxial Connections

Regulations governing the grounding of outer conductors on E1 coaxial pairs vary from country to country. To conform to these country-specific regulations, eight jumpers (one for Transmit and one for Receive on each port) are provided on the rear of the E1/T1/J1 and E1/T1/J1 IMA I/O cards (see Figure 1 on page 6 and Figure 2 on page 7)

- If a jumper is inserted over a pair of jumper pins, the outer connector of the corresponding port is grounded to the Frame Ground.
- If no jumper is inserted, the outer connector of that port is grounded through a 10 nF capacitor.

Normally, only the outer connector of the transmit port is to be grounded, and not the receive port. This depends on individual country regulations. Check to see whether your country also requires the receive port to be grounded.

Table 2. Ground Jumper Settings for E1 Coaxial Connections

To Ground Outer of:	Place Jumper On:	To Ground Outer of:	Place Jumper On:
Port 1 Receive	JP9	Port 3 Receive	JP13
Port 1 Transmit	JP10	Port 3 Transmit	JP14
Port 2 Receive	JP11	Port 4 Receive	JP15
Port 2 Transmit	JP12	Port 4 Transmit	JP16

Note: Standard G.703 recommends that the outer conductor of the coaxial pair be connected to ground on the transmit port, and that the same provision be available for the receive port. Some countries however, have different rules, so the setting may be not apply.

Mounting an E1/T1/J1 or E1/T1/J1 IMA on the Motherboard

Attention: When installing an I/O card on the motherboard, be careful not to touch the I/O card components. Always hold the card by its edges.

To mount the E1/T1/J1 I/O card or E1/T1/J1 IMA I/O Card on the motherboard, follow these steps:

- 1 Before mounting the I/O card on the motherboard, you must first isolate and then remove the module from the IBM 8260 Nways Multiprotocol Switching Hub, IBM 8285 Nways ATM Workgroup Switch, or IBM 8265 Nways ATM Switch. To isolate the module, enter the following command from the ATM console:

```
SET MODULE slot ISOLATED
```

where `slot` specifies the number of the slot to be used.
- 2 Detach the motherboard on which you want to install the I/O card by removing the four screws (1 and 2 in Figure 4) that hold the motherboard to the module. Save the screws in order to reattach the motherboard.

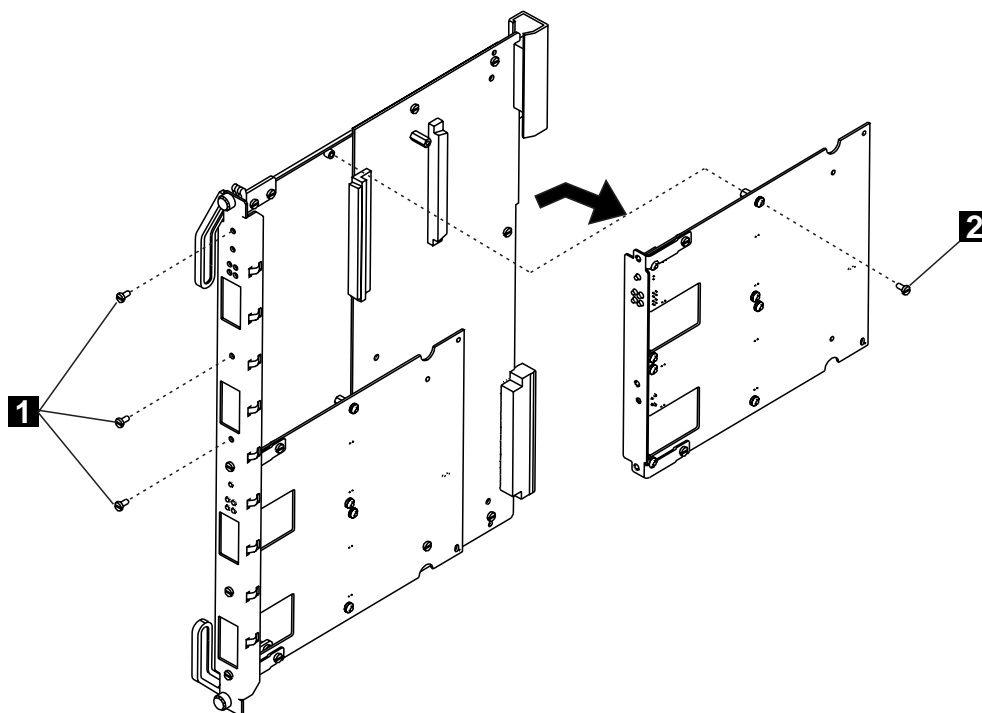

Figure 4. Removing the Motherboard

- **3** Disconnect the motherboard connectors and lift the motherboard out of the module.
- **4** Remove the dummy faceplate bracket from the motherboard (**3** in Figure 5), saving the screws for the new bracket. Save the dummy bracket in a safe place for future reuse.

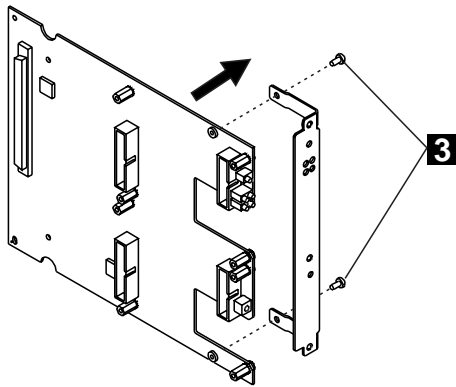

Figure 5. Removing the Dummy Faceplate Bracket

- **5** Attach the I/O card to the motherboard using the four screws provided (**4** in Figure 6).

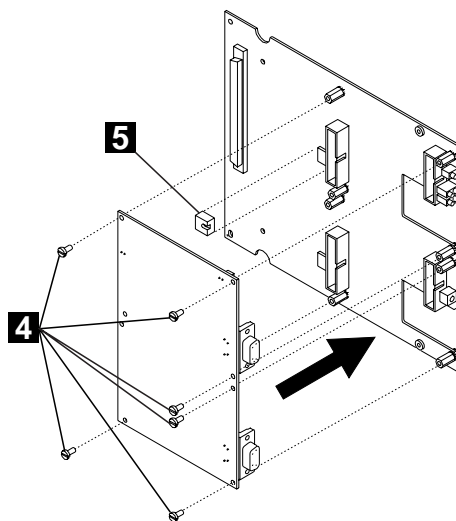

Figure 6. Attaching the I/O Card

- **6** Install the VPD PROM chip (**5**) on the motherboard, making sure that the notch is aligned with the front of the module.
- **7** Attach the faceplate bracket to the motherboard using the two screws (**6** in Figure 7) from the old dummy bracket.

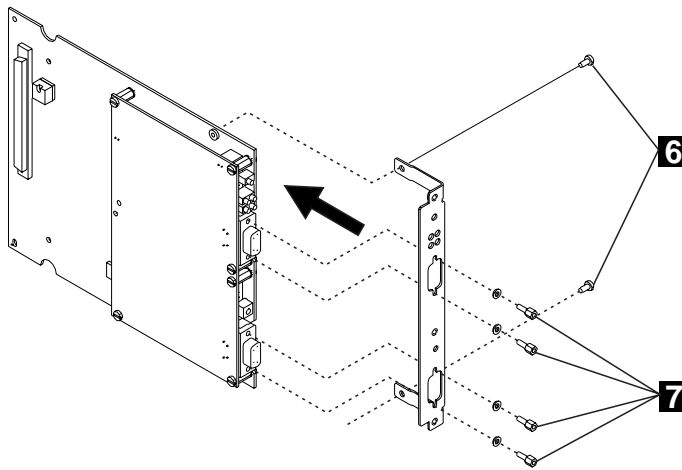

Figure 7. Attaching the Faceplate Bracket

- **8** Using a screwdriver, attach one post (**7**) onto each side of each of the two ports on the I/O card.
- **9** Hold the motherboard so that the connectors and screw holes are aligned correctly on the module. Then gently push the card downwards until you hear it click into the motherboard connectors.

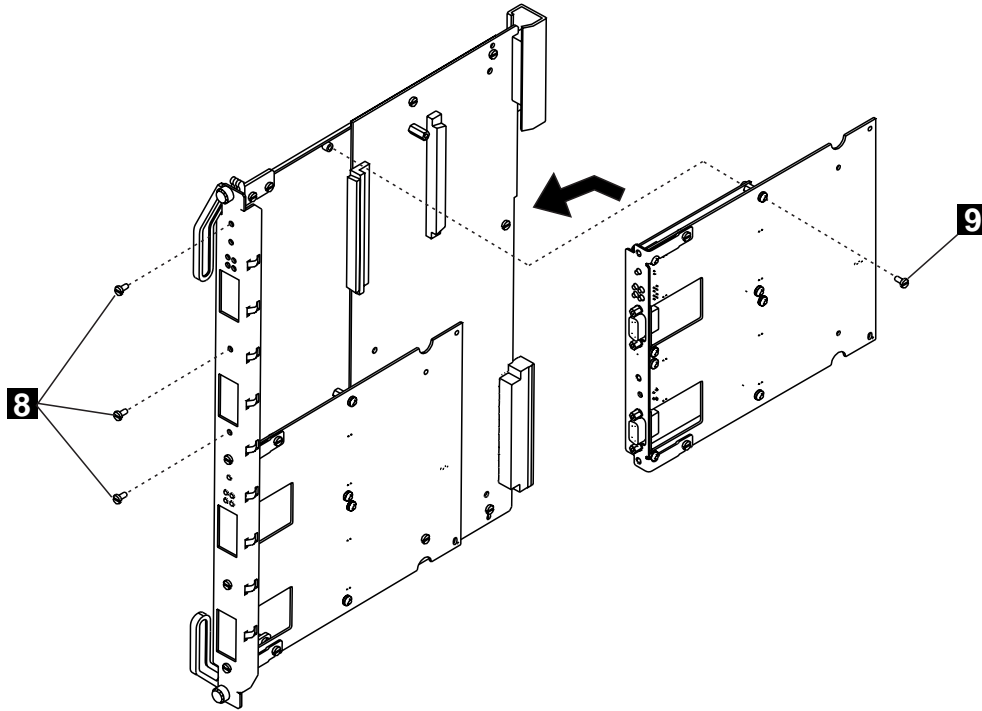

Figure 8. Reattaching the Motherboard

- **10** Reattach the motherboard to the module using the four screws (**8** and **9** in Figure 8) that you removed in Step 2 on page 10.

Chapter 4. Installing an E3, DS3, OC3, or STM1 I/O Card

This chapter describes the steps required to install an E3, DS3, OC3, or STM1 I/O card on the WAN module.

Note: One I/O card can be installed per motherboard.

Procedure

- **1 (E3/DS3 I/O cards only)** Ensure that the configuration of the grounding jumpers on the I/O card conforms to the specific grounding regulations in your country by following the instructions in “Setting the Grounding Jumpers for E3/DS3 I/O Cards” on page 16.

- **2 (OC3/STM1 I/O cards only)** If you are installing an I/O card on a WAN 2.5 module that was previously used on a WAN 2 module, check that the I/O card is supported. Supported OC3/STM1 I/O cards are as follows:
 - OC3 single-mode fiber, Part Number 02L3269
 - OC3 multimode fiber, Part Number 02L3275
 - STM1 single-mode, Part Number 02L3272
 - STM1 multimode, Part Number 02L3278

- **3** Mount the I/O card on the module by following the instructions in “Mounting an E3, DS3, OC3, or STM1 on the WAN Motherboard” on page 18.

- **4** Configure the I/O card as described in the *WAN Module User's Guide*.

Note: If you replace an I/O card after configuring the module, the new card is automatically configured with the settings of the previous card when you re-insert the module.

Setting the Grounding Jumpers for E3/DS3 I/O Cards

To adhere to country specific regulations regarding the grounding of outer conductors on coaxial pairs (both receive and transmit ports), four jumpers are provided on the rear of the E3/DS3 I/O cards. If the jumpers are not used, the outer connector is grounded through a 10 nF capacitor. Figure 9 shows the location of the four jumpers.

Normally, only the outer connector of the transmit port is to be grounded, and not the receive port. This depends on individual country regulations. Check to see whether your country also requires the receive port to be grounded.

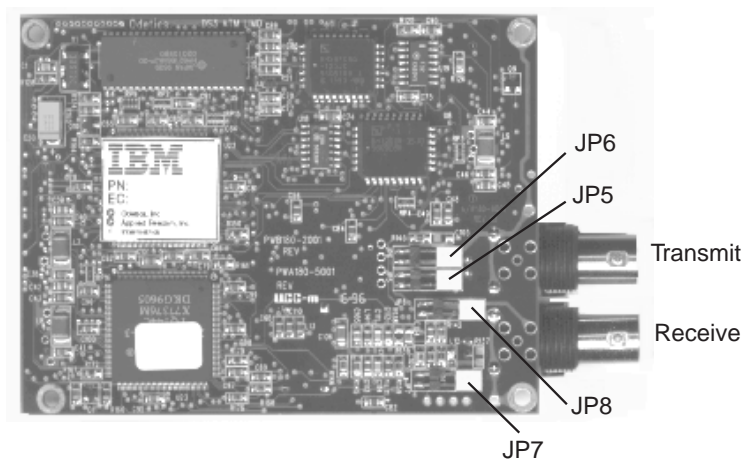

Figure 9. Grounding Jumper Locations

Refer to Table 3 to determine which jumpers you require to meet your country's requirements. Remove any jumpers that are not required by sliding them gently in the direction of the ports.

Attention: Some of the jumpers MUST be removed before the I/O card is installed..

Table 3. Grounding Jumper Requirements for E3/DS3 I/O Cards.

Outer of:	Connected to:	JP5	JP6	JP7	JP8
Transmit	Ground		√		
Transmit	0 volt	√			
Receive	Ground				√
Receive	0 volt			√	
E3 (According to G.703)		√	√		
DS3 (Recommended setting)		√	√	√	√

Note: Standard G.703 recommends that the outer conductor of the coaxial pair is connected to ground on the transmit port, and that the same provision be available for the receive port. Some countries however, have different rules, so the setting may not apply.

Mounting an E3, DS3, OC3, or STM1 on the WAN Motherboard

Attention: When installing an I/O card on the motherboard, be careful not to touch the I/O card components. Always hold the I/O card by its edges.

Note: Although the illustrations in this chapter show an E3 I/O card being installed, the steps are identical for the DS3, OC3, and STM1 I/O cards.

To install the I/O card on the WAN motherboard, follow these steps:

- **1** Before installing the I/O card on the module, you must first isolate and then remove the module from the IBM 8260 Nways Multiprotocol Switching Hub, IBM 8265 Nways ATM Switch, or IBM 8285 Nways ATM Workgroup Switch. To isolate the module, enter the following command from the ATM console:

```
SET MODULE slot ISOLATED
```

where `slot` specifies the number of the slot to be used.

- **2** Detach the motherboard on which you want to install the I/O card by removing the four screws (**1** and **2** in Figure 10 on page 19) that hold the motherboard to the module. Retain the screws for reattaching the motherboard.

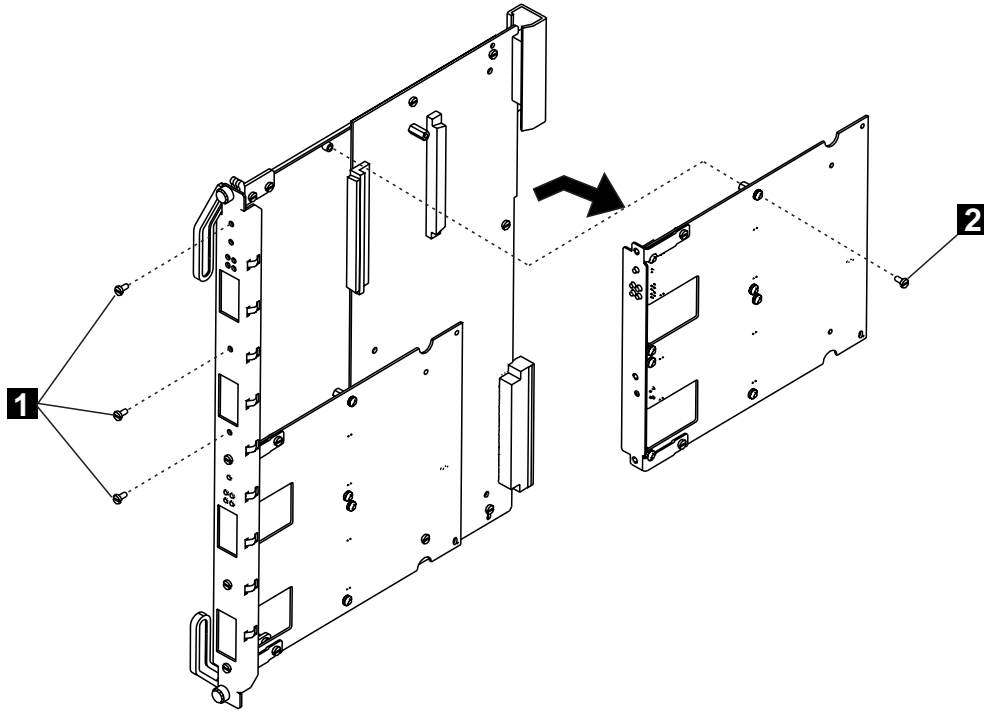

Figure 10. Removing the Motherboard

- 3 Disconnect the motherboard connectors and lift the motherboard out of the module.

- **4** Remove the dummy faceplate bracket from the motherboard (**3** in Figure 11), retaining the screws for the new bracket. Keep the dummy bracket in a safe place for future reuse.

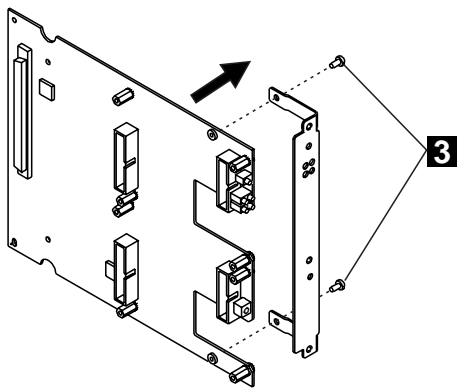

Figure 11. Removing the Dummy Faceplate Bracket

- **5** Attach the I/O card to the motherboard using the four screws provided (**4** in Figure 12).

Note: The I/O card must be installed in the **top position**.

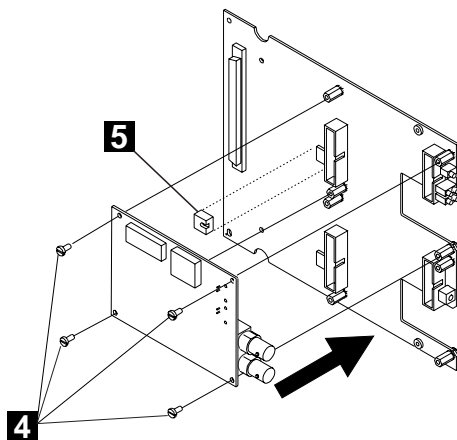

Figure 12. Attaching the I/O Card

- **6** Install the VPD PROM chip (**5**) on the motherboard, making sure that the notch is aligned with the front of the module.

- **7** Attach the faceplate bracket to the motherboard using the two screws (**6** in Figure 13) from the dummy bracket.

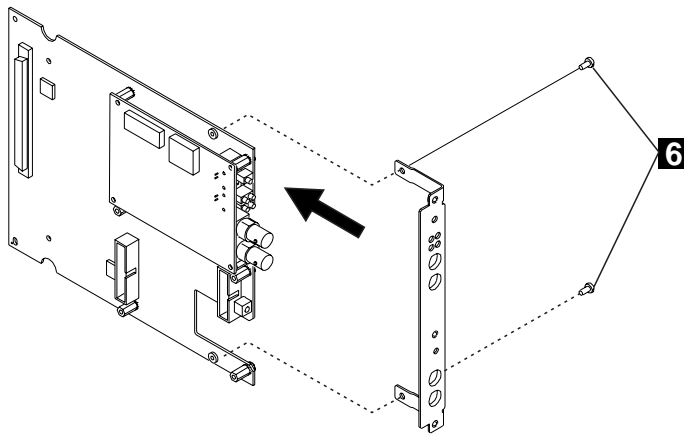

Figure 13. Attaching the Faceplate Bracket

- **8** Hold the motherboard so that the connectors and screw holes are aligned correctly on the module. Then gently push the card downwards until you hear it click into the motherboard connectors.
- **9** Reattach the motherboard to the module using the four screws (**7** and **8** in Figure 14 on page 22) that originally held the motherboard.

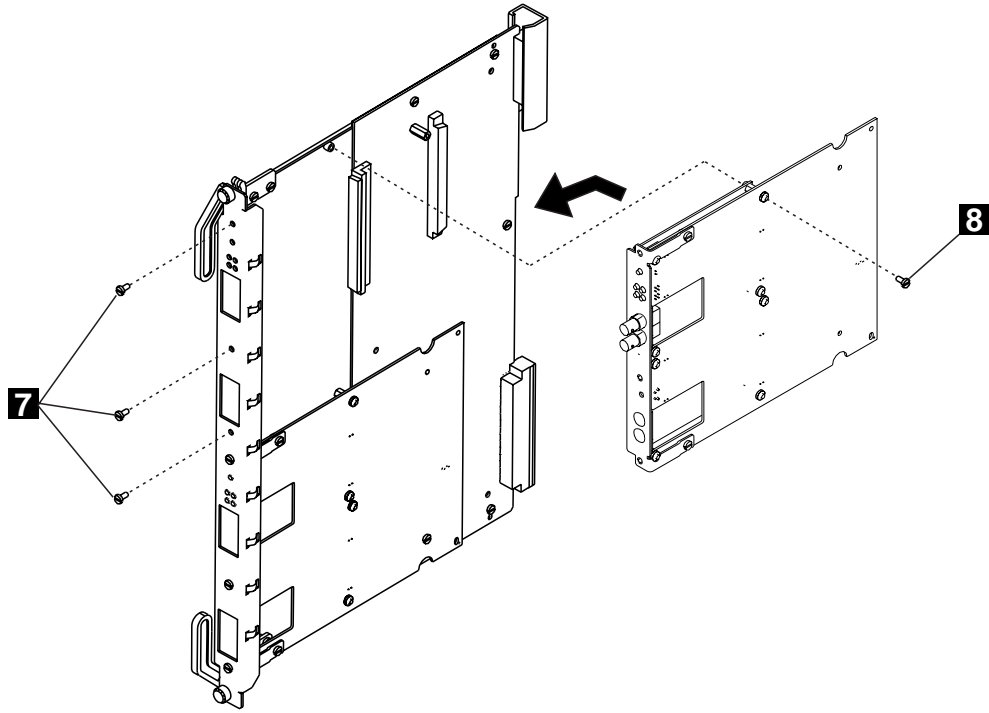

Figure 14. Reattaching the Motherboard

Appendix A. Technical Information

E1/T1/J1 and E1/T1/J1 IMA I/O Card

The E1/T1/J1 I/O Card conforms with:

- ANSI recommendations T1.102-1993 and T1.107-1995 for the line interface at 1.544 Mbps, and recommendations T1.646-1995 for the transportation mode.
- ITU G.703/G.704/G.706 recommendations for E1 at 2.048 Mbps.

The E1/T1/J1 IMA I/O Card conforms with:

- ATM Forum: AF-PHY-0016.000, AF-PHY-0064.000, and AF-HY-0086.000d
- ITU-TS: G.704, G.706, G.804, G.823, G.826, G.832, I.431, and I.610

Cabling Information

Table 4 details the accepted cable types for the E1/T1/J1 and E1/T1/J1 IMA ATM ports.

Table 4. E1/T1/J1 Cabling

Connection Type	Cable Type	Impedance	Attenuation
E1 (twisted-pair)	STP	120 ohm	6dB @ 1.024 MHz
T1/J1 (twisted-pair)	STP	100 ohm	15dB @ 772 KHz
E1 (coaxial)	RG59	75 ohm	6dB @ 1.024 MHz

Note: The values given assume that the attenuation follows approximately a \sqrt{f} law.

For more information, refer to the *IBM 8250 Multiprotocol Switching Hub*, *IBM 8260 Multiprotocol Intelligent Switching Hub*, *IBM 8285 Nways ATM Workgroup Switch, Planning and Site Preparation Guide*, GA33-0285, or the *IBM 8265 Nways ATM Switch Media Module Reference Guide*, GA33-0460.

Cabling Distances

Because the maximum recommended distance depends on the quality of cable used, the values given in Table 5 on page 24 are approximate.

Table 5. ATM Device Cabling Distances

Configuration Type	Cable Type	Maximum Recommended Distance
E1 (twisted-pair)	STP	230 meters
T1/J1 (twisted-pair)	STP	<i>Short-haul: 200 meters</i> <i>Long-haul: 750 meters</i>
E1 (coaxial)	RG59 coax	300 meters

E3/DS3 I/O Cards

The E3 I/O Card conforms with CCITT recommendation G.703 for the line interface at 34368 Kbps, and recommendation G.832 for the transportation mode.

The DS3 I/O Card conforms with ANSI recommendation T1.102-1993 for the line interface at 44736 Kbps, and recommendations T1.107-1988/T1.107a-1990 for the transportation mode.

The media for both I/O card types is a 75 ohm impedance coaxial pair with BNC connectors for each direction of transmission.

Cabling Information

Table 6 details the accepted coaxial cables for the ATM ports.

Table 6. Cabling Details

I/O Card Type	Cable Type	Impedance	Attenuation @ 400 MHz
E3	RG59	75 ohm	25dB MAX / 100m
DS3	RG59	75 ohm	25dB MAX / 100m

Note: The 25 dB attenuation @ 400 MHz corresponds to an attenuation of 12 dB @ 17 MHz, assuming that follows approximately a \sqrt{f} law.

For more information, refer to the *IBM 8250 Multiprotocol Switching Hub*, *IBM 8260 Multiprotocol Intelligent Switching Hub*, *IBM 8285 Nways ATM Workgroup Switch, Planning and Site Preparation Guide*, GA33-0285, or the *IBM 8265 Nways ATM Switch Media Module Reference Guide*, GA33-0460.

Cabling Distances

Because the maximum recommended distance depends on the quality of cable used, the values given in Table 7 are approximate.

Table 7. ATM Device Cabling Distances

I/O Card Type:	Cable Type	Maximum Recommended Distance
E3	RG59 coax	100 meters (330 ft) based on a power budget of 12 dB @ 17 MHz.
DS3	RG59 coax	68 meters (225 ft) default 135 meters (450 ft) If cable distance exceeds 68 meters (225 ft), the default configuration setting for the port must be changed. See the <i>WAN Module User's Guide</i> , SA33-0396.

OC3/STM1 I/O Cards - Single Mode

To use the technical information presented in this section to validate your link, see the chapter on setting up a connection using fiber in the *WAN Module User's Guide*.

Optical Power Budget

Table 8. Optical Power Budget for Port-to-Port Connections: Single-Mode Fiber

Fiber Cable: Type and Size	Minimum Transmitted Power	Maximum Received Power	Optical Power Budget	Maximum Link Distance
Single Mode 9/125 micron	-15 dB	-29 dB	14 dB	20 km (12.4 miles)

Optical Power Loss through Connectors

Table 9. Optical Power Loss per Connector: Single-Mode Fiber

Connector Type	Cable Size (microns)	Average Loss (dB)
Physical contact	9 to 9	0.35

Optical Power Loss through Splicing

Table 10. Optical Power Loss per Splice: Single-Mode Fiber

Splice Type	Cable Size (microns)	Maximum Loss (dB)	Average Loss (dB)
Fusion	9 to 9	—	0.15
Mechanical	9 to 9	1.0	0.4

Optical Power Loss by Fiber Cable Type

Table 11. Optical Power Loss by Cable Type: Single-Mode Fiber

Type of Fiber Cable	Power Loss (dB/km)	Typical Loss (dB/km)
9/125 micron @ 1300 nm	—	0.5

Optical Power Loss through Patch Panels

Table 12. Optical Power Loss per Patch Panel: Single-Mode Fiber

Type of Patch Panel	Power Loss	Typical Loss
SC to MIC	0.1 to 1.0 dB	0.6 dB
ST to SC	0.1 to 1.0 dB	0.6 dB
SC to SC	0.1 to 1.0 dB	0.6 dB

Optical Power Loss through Jumper Cables

Table 13. Optical Power Loss per IBM Jumper Cable: Single-Mode Fiber

Cable Type	Total Loss	By Component
Single Mode	0.75 dB	0.7 (0.35 × 2 connectors) + 0.05 (cable loss for 100 meters)

SC Single Mode Transmitters

Power coupled into fiber cable includes SC connector loss.

Table 14. Optical Specifications for SC Transmitters: Single-Mode Fiber

Parameter	Minimum Value	Typical Value	Maximum Value	Unit
Optical Power Output (P_O): 9/125 micron cable ¹	-15	—	-8	dBm avg
Center Wavelength (λ_c)	1261	1300	1360	nm
Modulation Frequency	—	155.52	—	MHz

Notes:

1. These optical power values are measured with the following conditions:

- At the Beginning Of Life (BOL).
- Over the specified operating voltage and temperature ranges.
- With HALT Line State (12.5 MHz square-wave) input signal.
- At the end of one meter of noted optical fiber with cladding modes removed.

The average power value can be converted to a peak power value by adding 3 dB.

SC Single Mode Receivers

Table 15. Optical Specifications for SC Receivers: Single-Mode Fiber

Parameter	Minimum Value	Typical Value	Maximum Value	Unit
Optical Power Input: Minimum at Window Edge ¹ (P _{IN Min} W)	—	—	-29	dBm avg
Maximum (P _{IN Max})	-8	—	—	dBm avg
Operating Wavelength (λ)	1261	—	1360	nm

Notes:

1. This specification is intended to indicate the performance of the receiver section of the transceiver when Input Optical Power signal characteristics are present per the following definitions. The Input Optical Power dynamic range from the minimum level (with a window time-width) to the maximum level is the range over which the receiver is guaranteed to provide output data with a Bit Error Ratio (BER) better than or equal to 2.5×10^{-10} .

OC3/STM1 I/O Cards - Multimode

To use the technical information presented in this section to validate your link, see the chapter on setting up a connection using fiber in the *WAN Module User's Guide*.

Optical Power Budget

Table 16. Optical Power Budget for Port-to-Device Connections: Multimode Fiber (ATM Forum V3.0)

Fiber Cable: Type and Size	Minimum Transmitted Power	Maximum Received Power	Optical Power Budget	Maximum Link Distance
Multimode 50/125 micron NA 0.20	-21 dB	-30 dB	9 dB	2 km (1.24 miles)
Multimode 62.5/125 micron NA 0.275	-20 dB	-29 dB	9 dB	2 km (1.24 miles)

Table 17. Optical Power Budget for Port-to-Port Connections: Multimode Fiber

Fiber Cable: Type and Size	Minimum Transmitted Power	Maximum Received Power	Optical Power Budget	Maximum Link Distance
Multimode 50/125 micron NA 0.20	-22.5 dB	-30 dB	7.5 dB	2 km (1.24 miles)
Multimode 62.5/125 micron NA 0.275	-19 dB	-30 dB	11 dB	2.2 km (1.36 miles)

Optical Power Loss through Connectors

Table 18. Optical Power Loss per Connector: Multimode Fiber

Connector Type	Cable Size (microns)	Average Loss (dB)
Physical contact	62.5 to 62.5	0.4
	50 to 50	0.4
	100 to 100	0.4
	62.5 to 50	4.8
	50 to 62.5	0.0
	62.5 to 100	0.0
	100 to 62.5	4.72
	9 to 9	0.35
Non-physical contact	62.5 to 62.5	0.7
	50 to 50	0.7
	100 to 100	0.7
	62.5 to 50	5.0
	50 to 62.5	0.3
	62.5 to 100	0.3
	100 to 62.5	4.9

Optical Power Loss through Splicing

Table 19. Optical Power Loss per Splice: Multimode Fiber

Splice Type	Cable Size (microns)	Maximum Loss (dB)	Average Loss (dB)
Fusion	62.5 to 62.5	—	0.15
	50 to 50	—	0.15
	100 to 100	—	0.15
	9 to 9	—	0.15
Mechanical	62.5 to 62.5	1.0	0.4
	50 to 50	1.0	0.4
	100 to 100	1.0	0.4
	9 to 9	1.0	0.4

Optical Power Loss by Fiber Cable Type

Table 20. Optical Power Loss by Cable Type: Multimode Fiber

Type of Fiber Cable	Power Loss (dB/km)	Typical Loss (dB/km)
50/125 micron @ 1300 nM	0.5 to 2.5	1.5
62.5/125 micron @ 1300 nM	0.5 to 2	1.5
85/125 micron @ 1300 nM	3 to 6	4.0
100/140 micron @ 1300 nM	3 to 6	5.0
9/125 micron @ 1300 nM	—	0.5

Optical Power Loss through Patch Panels

Table 21. Optical Power Loss per Patch Panel: Multimode Fiber

Type of Patch Panel	Power Loss	Typical Loss
SC to MIC	0.1 to 1.0 dB	0.6 dB
ST to SC	0.1 to 1.0 dB	0.6 dB
SC to SC	0.1 to 1.0 dB	0.6 dB

Optical Power Loss through Jumper Cables

Table 22. Optical Power Loss per IBM Jumper Cable: Multimode Fiber

Cable Type	Total Loss	By Component
Multimode	1.5 dB	1.4 (0.7 × 2 connectors) + 0.1 (cable loss for 100 meters)

SC Multimode Transmitters

Table 23. Optical Specifications for SC Transmitters: Multimode Fiber

Parameter	Minimum Value	Typical Value	Maximum Value	Unit
Optical Power Output (P_O):				
50/125 micron cable ^{1,2} NA 0.20 fiber	-22.5	-18	-14	dBm avg
62.5/125 micron cable ¹ NA 0.275 fiber	-19	-16	-14	dBm avg
Center Wavelength ³ (λ_c)	1270	1300	1380	nm
Modulation Frequency	—	155.52	—	MHz

Notes:

1. These optical power values are measured with the following conditions:

- At the Beginning Of Life (BOL).
- Over the specified operating voltage and temperature ranges.
- With HALT Line State (12.5 MHz square-wave) input signal.
- At the end of one meter of noted optical fiber with cladding modes removed.

The average power value can be converted to a peak power value by adding 3 dB.

2. This transmitter is available on special request with coupled optical power guaranteed into 50/125 micron fiber cables. The value will depend on the specific NA of the 50/125 micron fiber used.
3. This parameter complies with the FDDI PMD requirements for the tradeoffs between center wavelength, spectral width, and rise/fall times. The temperature coefficient of the center wavelength is typically +0.37 nm/°C.

SC Multimode Receivers

Table 24. Optical Specifications for SC Receivers: Multimode Fiber

Parameter	Minimum Value	Typical Value	Maximum Value	Unit
Optical Power Input: Minimum at Window Edge ¹ (P _{IN Min} W)	—	-34	-30	dBm avg
Maximum (P _{IN Max})	-14	-13	—	dBm avg
Operating Wavelength (λ)	1270	—	1380	nm
Modulation Frequency	—	155.52	—	MHz

Notes:

1. This specification is intended to indicate the performance of the receiver section of the transceiver when Input Optical Power signal characteristics are present per the following definitions. The Input Optical Power dynamic range from the minimum level (with a window time-width) to the maximum level is the range over which the receiver is guaranteed to provide output data with a Bit Error Ratio (BER) better than or equal to 2.5×10^{-10} .

Appendix B. Notices

References in this publication to IBM products, programs, or services do not imply that IBM intends to make these available in all countries in which IBM operates.

Any reference to an IBM product, program, or service is not intended to state or imply that only IBM's product, program, or service may be used. Any functionally equivalent product, program, or service that does not infringe any of IBM's intellectual property rights may be used instead of the IBM product, program, or service. Evaluation and verification of operation in conjunction with other products, except those expressly designated by IBM, is the user's responsibility.

IBM may have patents or pending patent applications covering subject matter in this document. The furnishing of this document does not give you any license to these patents. You can send license inquiries, in writing, to the IBM Corporation, IBM Director of Licensing, 500 Columbus Avenue, Thornwood, New York 10594, U.S.A.

Product Page/Warranties

The following paragraph does not apply to the United Kingdom or to any country where such provisions are inconsistent with local law.

INTERNATIONAL BUSINESS MACHINES CORPORATION PROVIDES THIS PUBLICATION "AS IS" WITHOUT WARRANTY OF ANY KIND, EITHER EXPRESS OR IMPLIED, INCLUDING, BUT NOT LIMITED TO, THE WARRANTIES OF MERCHANTABILITY OR FITNESS FOR A PARTICULAR PURPOSE.

Some states do not allow disclaimer of express or implied warranties in certain transactions, therefore this statement may not apply to you.

Trademarks

IBM and Nways are trademarks of International Business Machines Corporation.

Safety

These products comply with International and IBM safety standards.

For more information, see the *IBM Telecommunication Products Safety Handbook*, GA33-0126.

Readers' Comments — We'd Like to Hear from You

8260 Nways Multiprotocol Switching Hub
8265 Nways ATM Switch
8285 Nways ATM Workgroup Switch
ATM WAN 2 and WAN 2.5 Modules
I/O Card Installation Guide
Publication No. SA33-0437-02

Please send us your comments concerning this book. We will greatly appreciate them and will consider them for later releases of the present book.

If you prefer sending comments by FAX or electronically, use:

- FAX: 33 4 93 24 77 97
- IBM Internal Use: LGERCF at IBMFR
- Internet: lgercf@fr.ibm.com

In advance, thank you.

Your comments:

Name

Address

Company or Organization

Phone No.

Readers' Comments — We'd Like to Hear from You
SA33-0437-02



Cut or Fold
Along Line

Fold and Tape

Please do not staple

Fold and Tape

PLACE
POSTAGE
STAMP
HERE

IBM France
Centre d'Etudes et Recherches
Service 0798 - BP 79
06610 La Gaude
France

Fold and Tape

Please do not staple

Fold and Tape

SA33-0437-02

Cut or Fold
Along Line



Printed in U.S.A.

SA33-0437-02

